



Cleanroom Management International

We care for your compliance

MEASUREMENT SOLUTIONS

# CLEAN ROOM PANEL - CRP5



TECHNOLOGY

## RELIABLE MEASUREMENTS IN CLEAN ROOMS

- Measures differential pressure, humidity and temperature
- Designed specifically for clean rooms
- Removable humidity and temperature probes for simpler adjustment and cleaning
- FDA- and GAMP-compatible
- Digital communication via Ethernet RJ45 and/or MODBUS TCP / RTU
- Analog input and output signals freely configurable
- Glass front panel highly resistant to chemicals
- Optical operating elements for operation with protective gloves



**rotronic**

MEASUREMENT SOLUTIONS

# CLEAN ROOM PANEL - CRP5

## TAKE A CLOSE LOOK: THE MAIN ADVANTAGES AT A GLANCE.

The Clean Room Panel, which is fitted with a diaphragm sensor for differential-pressure measurement, is a top-quality device. Validated according to GMP directives, and with its well thought-out design, the CRP5 is optimized for applications in laboratories and clean rooms. Optical buttons, and the magnet-mounted, removable HC2-CRP humidity and temperature probe permit efficient and effective cleaning. Up to 6 measurement values and messages can be displayed via its graphical color display. The colors of the display can be adjusted individually. Alarms, such as faults, exceeded limit values, or warnings are highlighted on the CRP5 display, and can also be forwarded digitally via MODBUS, Ethernet, or relays. Thanks to its analog and digital communication capabilities, the CRP5 is very easy to integrate in any monitoring system. Its comprehensive functional capabilities allow the CRP5 to be configured perfectly for each application. The CRP5 is distinctive in the marketplace through its tough glass front plate and a removable humidity sensor.

### Proven housing

- Robust, resistant glass front plate
- Protection Class IP65
- Installation in the wall of the clean room

### Functional display

- Measurement values displayed on a color graphics display with trend indicator and alarm signaling
- Configuration possible via 4 optical buttons

### Power supply

- 20...48 VDC / 18...35 VAC

### Communication

- 4 analog outputs: freely allocatable and scalable
- 2 analog inputs
- 2 digital inputs
- Ethernet RJ45; MODBUS TCP / RTU
- 6 solid-state relays

### Interchangeable probe

- Removable humidity and temperature probe HC2-CRP
- Simple probe calibration outside the room being monitored
- Alternatively: External HygroClip2 probe for detached humidity and temperature measurement



## THE APPLICATIONS

The CRP5 clean-room panel is the obvious choice wherever a high degree of cleanliness is vital, in addition to precise measurement of differential pressure, humidity, and temperature. The CRP5 is used particularly in clean-rooms in hospitals, in the pharmaceutical, electronics, and foodstuffs industries, and wherever small variances in pressure are monitored. The very comprehensive functional capabilities of the CRP5 provide solutions for many measurement and control tasks.



## THE PROBES FOR THE CRP5.

The HygroClip2 is available in various versions. From simple standard probes up to highly developed cable probes for high-temperature or other special applications, you will find exactly the probe that you need in our product range. What they all have in common is the high precision, reliability, and long-term stability that individual adjustment assures. And that is precisely what makes each probe in our range a high-end product for normal and industrial applications.

### Clean-room probe HC2-CRP



Precision:  $\pm 1.5\%RH$   
Range of application:  $-5...60^{\circ}C$   
Probes in stainless steel  
Magnetic attachment to the CRP5



### Any Rotronic probe



Precision: up to  $\pm 0.5\%RH$   
Range of application:  $-100...200^{\circ}C$   
Plastic, stainless-steel  
and screw-in versions  
Screw connection via Rotronic E2 plug



Would you like more information (special applications, ordering codes, etc.) on the choice of the correct probe?  
You will find a complete and always up-to-date overview of all our probes at our web site [www.rotronic.com](http://www.rotronic.com).

## TECHNICAL INFORMATION



HC2-CRP

### Clean-room probe HC2-CRP

|                          |                               |
|--------------------------|-------------------------------|
| Range of application     | -5...60 °C / 0...100 %RH      |
| Precision @ 23 °C ±3 K   | ±1.5 %RH / ±0.2 K             |
| Power supply             | 3.3...5 VDC                   |
| Current consumption      | 3.5 mA                        |
| Long-term stability      | <1 %RH / year                 |
| Sensor                   | HYGROMER® WA-1                |
| Filtertype               | Teflon, 5 µm                  |
| Response time            | 49 s                          |
| Connection               | Spring contacts gold plated   |
| Housing material         | Stainless steel 1.4301 / PEEK |
| Weight / Protection type | 155 g / IP65                  |



HC2-CRP-HOLDER

### Holder HC2-CRP HOLDER

|                      |                           |
|----------------------|---------------------------|
| Range of application | -5...60 °C / 0...100 %RH  |
| Connection           | Gold contacts / PicoBlade |
| Housing material     | PEEK                      |
| Protection type      | IP65                      |



AC6102

ER-CRP

### Accessories

#### Assembly accessories

|                               |   |
|-------------------------------|---|
| 2 off Wall bracket            | AC6101                                      |
| 4 off PEEK screws             | AC6102                                      |
| Service cable                 | AC3006 (requires HW4 software)              |
| Covers, pressure connections  | AC6100 (without hole)<br>AC6100 (with hole) |
| Calibration jig               | ER-CRP                                      |
| Calibration jig for HygroGen2 | ER-CRP-HG2                                  |
| Cable 10cm, open end          | PB-15-PB                                    |
| Cable A for PicoBlade         | A-80-PB                                     |
| Teflon filter                 | SP-CRP                                      |

## TECHNICAL INFORMATION.

### Technical drawings, CRP5

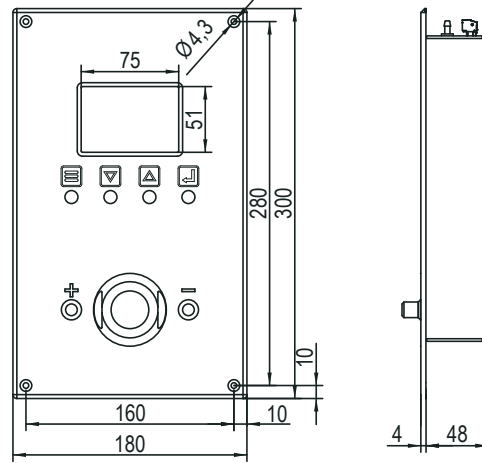
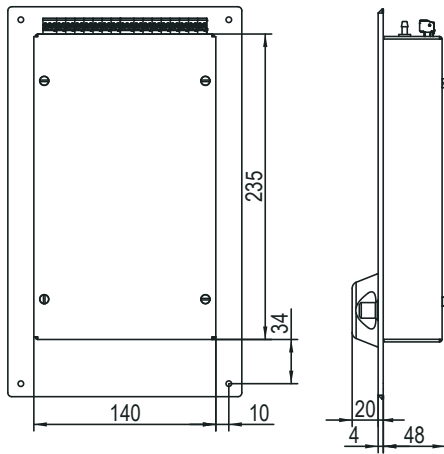

With front-mounted probe HC2-CRP

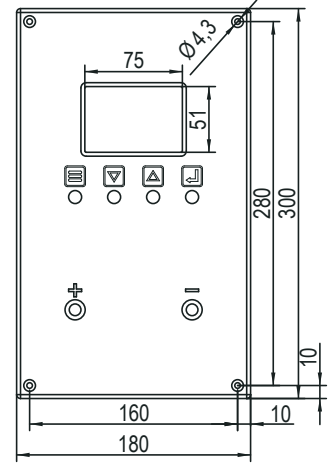

With HygroClip2 connection on back

### HC2-CRP

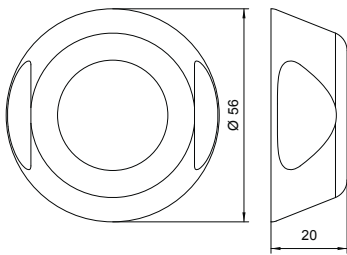

### HC2-CRP Holder

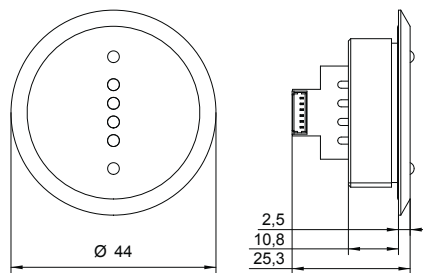

### CRP Wall Bracket

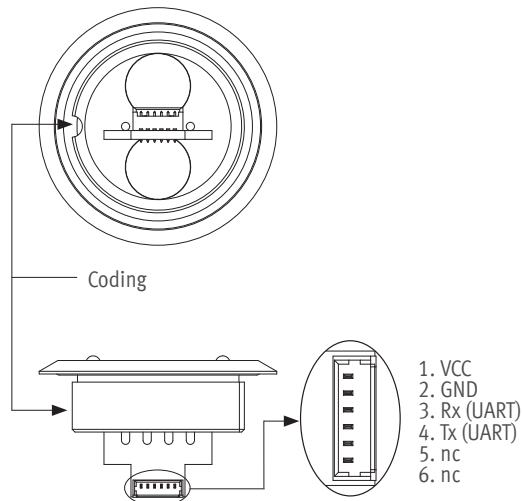
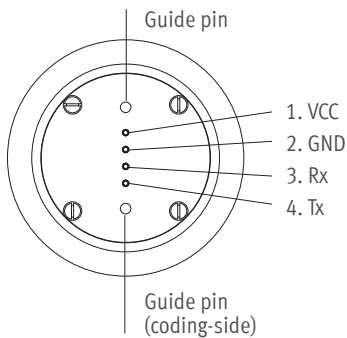
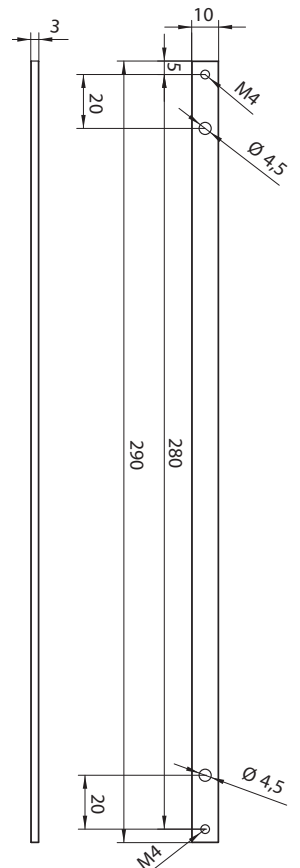

## TECHNICAL DATA.

| <b>General</b>   |  |
|--|--|
| Parameters   | Differential pressure, temperature, relative humidity, digital and analog inputs     |
| Housing material   | Front: Glass<br>Back: Stainless Steel  |
| IP protection  | Front: IP65 (also with sensors removed)<br>Back: IP20                                |
| Mounting position  | Wall Mounting  |
| Display  | Color TFT display  |
| Menu Navigation  | 4 optical buttons  |
| Electrical connections   | Screw terminals on back  |
| Power supply   | 20...48 VDC / 18...35 VAC  |
| Current Consumption  | <500 mA  |
| Range of application / Storage conditions                      | -5...60 °C (23...140 °F) / 0...100%RH  |
| Firmware update  | via HW4 software   |
| Service interface  | UART   |
| CE / EMC compatibility   | EMC Directive 2004/108/EC  |
| Fire protection class  | Corresponds to UL94-HB   |
| FDA- / GMP compatible  | 21 CFR Part 11 and GAMP5   |
| Dimensions   | 180x300x72 mm  |
| Weight   | 1,700 g (with humidity sensor)<br>1,550 g (without humidity sensor)                  |
| <b>Differential Pressure Measurement</b>                       |  |
| Measurement principle  | Diaphragm sensor   |
| Measurement ranges   | ±50 Pa / ±100 Pa / ±250 Pa / ±500 Pa   |
| Medium   | Air and non-aggressive gases   |
| Accuracy at 23 °C ±3 K   | ±1.0 % full-scale  |
| Zero drift   | Compensated (manual or automatic zero adjustment)                                    |
| Measurement interval   | 1 s  |
| Pressure resistance  | 0.7 bar (70,000 Pa)  |
| Pressure connections   | Front: Hose connectors Ø 6 mm x 10 mm<br>Back: Hose connectors Ø 4 mm x 10 mm        |
| <b>Temperature measurement / Relative-humidity measurement</b> |  |
| Probes   | HC2-CRP; alternatively: any HygroClip2 probe   |
| Measurement range  | -100...200 °C (probe-dependent) / 0...100 %RH  |
| <b>Outputs</b>   |  |
| Analog outputs   | 4, freely configurable   |
| Analog output type   | 0 / 4...20 mA or 0...1 / 5 / 10 V  |
| Switch output  | 6 solid-state relays   |
| Switching capacity   | <50 VDC at <2 A when observing polarity<br><35 VAC at <1 A, irrespective of polarity |
| Accuracy, analog output  | ±5 mV (voltage output)<br>±20 µA (current output)                                    |
| Permissible load   | >10 kΩ (voltage output)<br><500 Ω (current output)                                   |
| Digital communication  | Ethernet (Modbus TCP, HW4) / RS-485 (Modbus RTU, HW4)                                |

**CMI BELGIUM**  
Avenue de Ramelot 3  
B - 1480 Saintes (Sint Renelde)  
Tel : +32 (0)2 531 11 21  
info@cmitest.com

**CMI FRANCE**  
Ecoparc d'Affaires  
F- 41210 Neung-sur-Beuvron  
Tel : +33 (0)2 54 95 70 95  
infofr@cmitest.com

Agence Rhône Alpes :  
F- 26160 La Bégude-de-Mazenc  
Tel : +33 (0)4 75 54 57 26



[www.cmitest.com](http://www.cmitest.com)